

Save space and improve your workplace ergonomics !!!!

Desk Mount LCD Arm

Model : EA-111
(mounting via Desk Clamp w/foot A)



Monitor Tilt: 180 degrees.
Monitor Pan: 260 degrees.
Monitor Rotation: 90 degrees RIGHT/LEFT.

Model : EA-112
(mounting via Grommet w/foot B)



Arm Vertical adjustment: up 75 degrees.
Arm Rotation: 360 degrees.

Feature

- Supports 12~22 inches LCD monitors
- Rotating portrait and landscape of LCD monitor for better views.
- Upgrade LCD monitors with improved ergonomic adjustment.
- Simple installation -Mounting LCD monitor via desk Clamp/Grommet.
- Extends/retracts LCD monitor path; push your display out of the way when not in use.
- Cable management feature routes cables under the arm, out of the way.
- Mounting Standards: VESA FDMI MIS-D, 100&75, C (hole pattern: 100 x 100 mm & 75 x 75 mm)
- Color: Black or Silver.
- Warranty: 2 years or 5000 times for life of spring.

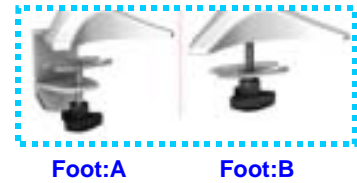

Foot:A

Foot:B

Product Data

MODEL NO.	Color	Wt. Capacity	Shipping Dim.	Shipping Weight
EA-111/112-5S	Silver	3-5 kg (6.6-11.0 lbs)	1.03 cu.ft.	3.5/4.6 kg(7.7-10.1 lbs)
EA-111/112-5B	Black	3-5 kg (6.6-11.0 lbs)	1.03 cu.ft.	3.5/4.6 kg(7.7-10.1 lbs)
EA-111/112-9S	Silver	5-9 kg (11.0-19.8 lbs)	1.03 cu.ft.	3.5/4.6 kg(7.7-10.1 lbs)
EA-111/112-9B	Black	5-9 kg (11.0-19.8 lbs)	1.03 cu.ft.	3.5/4.6 kg(7.7-10.1 lbs)

Create an Ergonomic Workstation for your Notebook Computer !!!!

Desk Mount LCD Arm with Notebook Tray

Model : EA101-PNB/ EA102-PNB
(with foot:A / with foot:B)



Feature

- Supports 12~22 inches LCD monitors
- Rotating portrait and landscape of LCD monitor for better views.
- Cable management helps organizing cables neat.
- Simple attachment and compatible with most Notebook.
- Adjustable and open-side mounting plated allows any size Notebook computer.
- A plate kit for Notebook computer (suitable for model No. EA-111/112: Desk LCD Mount Arm mounting via desk clamp/grommet).
- Color: Black or Silver.
- Warranty: 2 years.



Foot:A

Foot:B

Product Data

MODEL NO.	Color	Wt. Capacity	Shipping Dim.	Shipping Weight
EA101-PNB-S	Silver	Up to Max. 9 kgs (19.8 lbs)	1.37 cu.ft.	13.4/15.6 kg (29.52-34.36 lbs)
EA102-PNB-B	Black	Up to Max. 9 kgs (19.8 lbs)	1.37 cu.ft	13.4/15.6 kg (29.52-34.36 lbs)

**Save space and improve
your workplace ergonomics !!!!**

Desk Mount LCD Arm

Model : EA-111-P2

(mounting via Desk Clamp for Dual Displays)



Feature

- *Constructed of high quality aluminum alloy.*
- *Adjusts easily for flat to significantly concave monitor arrangements*
- *Supports dual displays with diagonal screen-size from 12 up to 22 inches.*
- *Upgrade LCD monitors with improved ergonomic adjustment.*
- *Simple installation and easy operation-Mounting LCD monitor via desk clamp.*
- *Advanced cable management design, Cables under the arm out of the way.*
- *Mounting Standards: VESA FDMI MIS-D, 100&75, C (hole pattern: 100 x 100 mm & 75 x 75 mm)*
- *Color: Black or Silver.*
- *Warranty: 2 years.*

Product Data

MODEL NO.	Color	Wt. Capacity	Shipping Dim.	Shipping Weight
EA-111-P2-S	Silver	Up to Max. 9 kgs (19.8 lbs)	0.85 cu.ft.	3.9/4.9 kg(8.6-10.8 lbs)
EA-111-P2-B	Black	Up to Max. 9 kgs (19.8 lbs)	0.85 cu.ft.	3.9/4.9 kg(8.6-10.8 lbs)

**Save space and improve
your workplace ergonomics !!!!**

Desk Mount LCD Arm

Model : EA-111-P3

(mounting via Desk Clamp for Triple Displays)



Feature

- *Constructed of aluminum and steel.*
- *Easily swivel, tilt, fold, or rotate your LCDs to perfection.*
- *Supports triple displays with diagonal screen-size from 12 up to 22 inches.*
- *Upgrade LCD monitors with improved ergonomic adjustment.*
- *Simple installation and easy operation-Mounting LCD monitor via desk clamp.*
- *Advanced cable management design, Cables under the arm out of the way.*
- *Mounting Standards: VESA FDMI MIS-D, 100&75, C (hole pattern: 100 x 100 mm & 75 x 75 mm)*
- *Color: Black or Silver.*
- *Warranty: 2 years.*

Product Data

MODEL NO.	Color	Wt. Capacity	Shipping Dim.	Shipping Weight
EA-111-P3-S	Silver	Up to Max. 9 kgs (19.8 lbs)	0.85 cu.ft.	5.6/6.7 kg(12.3-14.7 lbs)
EA-111-P3-B	Black	Up to Max. 9 kgs (19.8 lbs)	0.85 cu.ft.	5.6/6.7 kg(12.3-14.7 lbs)

**Save space and improve
your workplace ergonomics !!!!**

Wall Mount LCD Arm

Model : EA-114-A1



Monitor Tilt: 180 degrees.
Monitor Rotation: 90 degrees RIGHT/LEFT.

Arm left/right Rotation: 90/90 degrees.

Feature

- *Firmly mounts to solid wall.*
- *Supports 12~22 inches LCD monitors.*
- *Constructed of high quality aluminum alloy.*
- *Upgrade LCD monitors with improved ergonomic adjustment.*
- *Rotating portrait and landscape of LCD monitor for better views.*
- *Cable management feature routes cables under the arm, out of the way.*
- *Mounting Standards: VESA FDMI MIS-D, 100&75, C (hole pattern: 100 x 100 mm & 75 x 75 mm)*
- *Color: Black or Silver.*
- *Warranty: 2 years.*

Product Data

MODEL NO.	Color	Wt. Capacity	Shipping Dim.	Shipping Weight
EA-114-A1-S	Silver	Up to Max. 9 kgs (19.8 lbs)	0.17 cu.ft.	1.25-1.75 kg (2.7-3.8 lbs)
EA-114-A1-B	Black	Up to Max. 9 kgs (19.8 lbs)	0.17 cu.ft.	1.25-1.75 kg (2.7-3.8 lbs)

**Save space and improve
your workplace ergonomics !!!!**

Wall Mount LCD Arm

Model : EA-114-A2



Monitor Tilt: 180 degrees.
Monitor Pan: 260 degrees.
Monitor Rotation: 90 degrees RIGHT/LEFT.

Arm left/right Rotation: 180/180 degrees.
Arm Vertical adjustment: 75 degrees.

Feature

- *Firmly mounts to solid wall.*
- *Supports 12~22 inches LCD monitors.*
- *Constructed of high quality aluminum alloy.*
- *Upgrade LCD monitors and TVs with improved ergonomic adjustment.*
- *Rotating portrait and landscape of LCD monitor for better views.*
- *Cable management feature routes cables under the arm, out of the way.*
- *Mounting Standards: VESA FDMI MIS-D, 100&75, C (hole pattern: 100 x 100 mm & 75 x 75 mm)*
- *Color: Black or Silver.*
- *Warranty: 2 years or 5000 times for life of spring.*

Product Data

MODEL NO.	Color	Wt. Capacity	Shipping Dim.	Shipping Weight
EA-114-A2-5S	Silver	3-5 kg (6.6-11.0 lbs)	0.49 cu.ft.	2.1-2.8 kg (4.6-6.2 lbs)
EA-114-A2-5B	Black	3-5 kg (6.6-11.0 lbs)	0.49 cu.ft.	2.1-2.8 kg (4.6-6.2 lbs)
EA-114-A2-9S	Silver	5-9 kg (11.0-19.8 lbs)	0.49 cu.ft.	2.1-2.8 kg (4.6-6.2 lbs)
EA-114-A2-9B	Black	5-9 kg (11.0-19.8 lbs)	0.49 cu.ft.	2.1-3.8 kg (4.6-6.2 lbs)

**Save space and improve
your workplace ergonomics !!!!**

Wall Mount LCD Arm

Model : EA-114-A3



Monitor Tilt: 180 degrees.
Monitor Pan: 260 degrees.
Monitor Rotation: 90 degrees RIGHT/LEFT.

Arm Vertical adjustment: up 75 degrees.
Arm Rotation: 360 degrees.

Feature

- *Firmly mounts to solid wall.*
- *Supports 12~22 inches LCD monitors.*
- *Constructed of high quality aluminum alloy.*
- *Upgrade LCD monitors with improved ergonomic adjustment.*
- *Rotating portrait and landscape of LCD monitor for better views.*
- *Cable management feature routes cables under the arm, out of the way.*
- *Mounting Standards: VESA FDMI MIS-D, 100&75, C (hole pattern: 100 x 100 mm & 75 x 75 mm)*
- *Color: Black or Silver.*
- *Warranty: 2 years or 5000 times for life of spring.*

Product Data

MODEL NO.	Color	Wt. Capacity	Shipping Dim.	Shipping Weight
EA-114-A3-5S	Silver	3-5 kg (6.6-11.0 lbs)	0.58 cu.ft.	2.5-3.3 kg (5.5-7.3 lbs)
EA-114-A3-5B	Black	3-5 kg (6.6-11.0 lbs)	0.58 cu.ft.	2.5-3.3 kg (5.5-7.3 lbs)
EA-114-A3-9S	Silver	5-9 kg (11.0-19.8 lbs)	0.58 cu.ft.	2.5-3.3 kg (5.5-7.3 lbs)
EA-114-A3-9B	Black	5-9 kg (11.0-19.8 lbs)	0.58 cu.ft.	2.5-3.3 kg (5.5-7.3 lbs)

**Save space and improve
your workplace ergonomics !!!!**

LCD / Plasma TV Wall Mount Kit ~ F series

Model : EA-W10-F1

(for Panel TV under 42 inches)

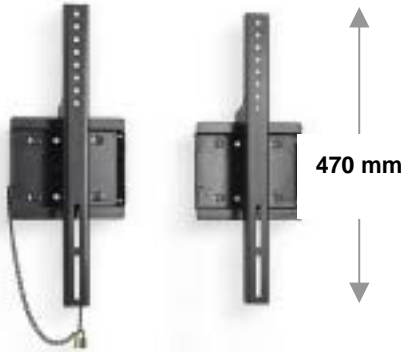

Model : EA-W10-F2

(for Panel TV : 42-63 inches)

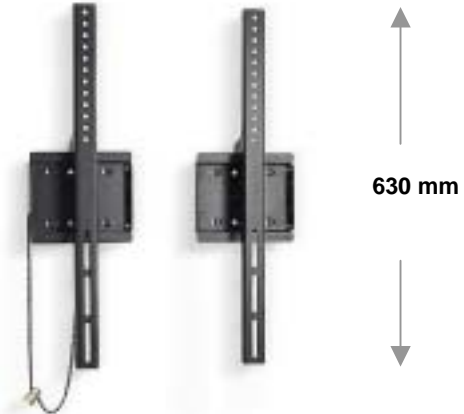

Feature

- Firmly mounts to solid wall.
- Constructed of high quality steel.
- Fixed type.
- Model : EA-W10-F1, supports Flat Panel TV, size under 42 inches.
- Model : EA-W10-F2, supports Flat Panel TV, size 42 to 63 inches.
- Mounting Standards: VESA FDMI MIS-E&F.
- Color: Black.
- Warranty: 2 years.

Product Data

MODEL NO.	Color	Wt. Capacity	Shipping Dim.	Shipping Weight
EA-W10-F1	Black	Flat Panel TV under 42 inches (Up to Max.50 kgs)	0.19 cu.ft.	3.5/3.7 kg(7.7-8.2 lbs)
EA-W10-F2	Black	Flat Panel TV: 42~63 inches (Up to Max.50 kgs)	0.23 cu.ft.	3.9/4.2 kg(8.6-9.3 lbs)

**Save space and improve
your workplace ergonomics !!!!**

LCD / Plasma TV Wall Mount Kit ~ T series

Model : EA-W10-T1
(for Panel TV under 42 inches)

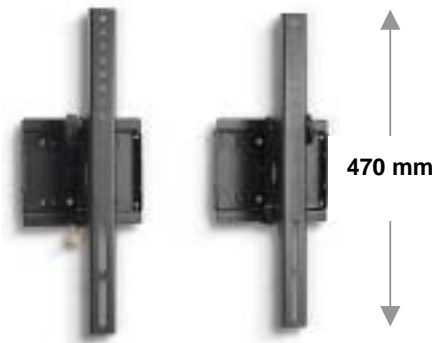

Model : EA-W10-T2
(for Panel TV : 42-63 inches)

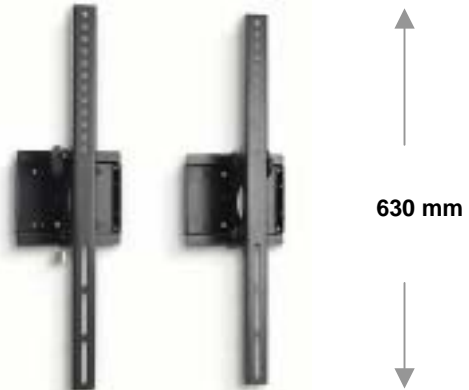

Pivots upward & downward: -5 to 15 degrees.

- *Firmly mounts to solid wall.*
- *Constructed of high quality steel.*
- *Pivots upward & downward: -5 to 15 degrees.*
- *Model : EA-W10-T1 supports Flat Panel TV, size under 42 inches.*
- *Model : EA-W10-T2 supports Flat Panel TV, size 42 to 63 inches.*
- *Mounting Standards: VESA FDMI MIS-E&F.*
- *Color: Black.*
- *Warranty: 2 years.*

Product Data

MODEL NO.	Color	Wt. Capacity	Shipping Dim.	Shipping Weight
EA-W10-T1	Black	Flat Panel TV under 42 inches (Up to Max.50 kgs)	0.37 cu.ft.	4.7/5.0 kg(10.3-11 lbs)
EA-W10-T2	Black	Flat Panel TV 42~63 inches (Up to Max.80 kgs)	0.96 cu.ft.	5.0/5.4 kg(11.0-11.9 lbs)

**Save space and improve
your workplace ergonomics !!!!**

LCD / Plasma TV Wall Mount Kit ~ V series

Model : EA-W10-V1

Model : EA-W10-V2

Model : EA-W10-VR1

(Designed for Panel TV under 37 inches)



Fixed type.



Pivots upward & downward:
-5 to 15 degrees.



Provide up and down, left and right, front
and back pivot and tilting capability.

Feature

- *Firmly mounts to solid wall.*
- *Constructed of high quality steel.*
- *Model : EA-W10-VR1 provides Cable Management., helps organizing cables neat.*
- *Type V2&VR1: Pivots upward & downward: -5 to 15 degrees.*
- *Supports LCD monitors & Flat Panel TV, size under 37 inches.*
- *Mounting Standards: VESA MIS-D/E,C, hole pattern: 200 x 200 mm, 200 x 100 mm, 100 x 100 mm & 75 x 75 mm)*
- *Color: Black.*
- *Warranty: 2 years.*

Product Data

MODEL NO.	Color	Wt. Capacity	Shipping Dim.	Shipping Weight
EA-W10-V1	Black	LCD display/TV under 37 inches (Up to Max.50 kgs)	0.14 cu.ft.	1.73/1.93 kg(3.8-4.3 lbs)
EA-W10-V2	Black	LCD display/TV under 37 inches (Up to Max.50 kgs)	0.18 cu.ft.	3.2/3.4 kg(7.0-7.5 lbs)
EA-W10-VR1	Black	LCD display/TV under 37 inches (Up to Max.40 kgs)	0.73 cu.ft.	7.0/7.6 kg(15.4-16.7 lbs)